



Änderungen vorbehalten!

Subject to change!

Modifications réservées!

Pos.	Artikel Article Article	Typ Type Type	Esco 5	Esco 10	Esco 20	Esco 30	Esco Niro 10	Esco Niro 20	Art.-/SAP-Nr. Art.-/SAP-No. Art.-/SAP-No.
101	Drehantrieb	CA75	1	1					1101096
	Rotary disk actuator	CA150A	1	1	1	1	1	1	2556606
	Servomoteur rotatif	CA150A-S	1	1	1	1	1	1	2556607
102	Pneumatik-Antrieb inkl. Stellungsregler		1	1					1117621
	Pneumatic actuator with positioner				1	1			1117622
	Servomoteur pneumatique avec positionneur						1		2520510
102	Pneumatik-Antrieb ohne Stellungsregler		1	1					2520816
	Pneumatic actuator without positioner				1	1			2520817
	Servomoteur pneumatique sans positionneur						1		2520818
---	Stellungsregler für Pneumatik-Antrieb		1	1	1	1	1	1	1101104
	Positioner for pneumatic actuator								
	Positionneur pour servomoteur pneumatique								
103	Festscheibe inkl. Dichtungen	5/10/Niro10	1	1			1		1118047
	Ceramic disc fixed, gasket incl.	20			1				1118048
	Disque ceramic fixe, joint incl.	30				1			1118049
		Niro20						1	2557347
104	Losscheibe inkl. Dichtung Ceramic rotary disc, gasket incl. Disque ceramic rotatif, joint incl.	5.1 / 10.1	1	1					1118066
		5.2 / 10.2	1	1					1118067
		5.3 / 10.3	1	1					1118068
		5.4 / 10.4	1	1					1118069
		5.5 / 10.5	1	1					1118070
		5.6 / 10.6	1	1					1118071
		5.7 / 10.7	1	1					1118072
		10.8		1					1118073
		10.9		1					1118074
		10.10		1					1118075
		20.1			1				1118086
		20.2			1				1118087
		20.3			1				1118088
		20.4			1				1118089
		30.1					1		1118090
		30.2					1		1118091
		30.3					1		1118092
		30.4					1		1118093
		Niro10.1						1	1118076
		Niro10.2						1	1118077
		Niro10.3						1	1118078
		Niro10.4						1	1118079
		Niro10.5						1	1118080
Niro10.6						1	1118081		
Niro10.7						1	1118082		
Niro10.8						1	1118083		
Niro10.9						1	1118084		
Niro10.10						1	1118085		
Niro20.1							1	2557343	
Niro20.2							1	2557344	
Niro20.3							1	2557345	
Niro20.4							1	2557346	
105	Dichtungsset Set Gaskets Set joints		1						1118030
				1					1118031
					1				1118032
						1			1118033
							1		1118034
								1	2557342

Pos.	Artikel Article Article	Typ Type Type		Esco 5	Esco 10	Esco 20	Esco 30	Esco Niro 10	Esco Niro 20	Art.-/SAP-Nr. Art.-/SAP-No. Art.-/SAP-No.	
106	Welle + Stopfbüchse kpl. Shaft + stuffing box cpl. Arbre + presse-étoupe cpl.	CA150 (-S) / CA150A (-S)	ASF		1					1118035	
			ASF		1					1118036	
			CA75		1						1118037
			pneum.		1						1118038
			CA150 (-S) / CA150A (-S)			1					1118039
			ASF			1					1118040
			CA75			1					1118041
			pneum.			1					1118042
			ASF						1		1118043
			CA150 (-S) / CA150A (-S)						1		1118044
107	Thermischer Primär-Kondensatableiter Thermostatic primary steam trap Purgeur de vapeur thermostatique primaire		1							2577014	
107	Glockenschwimmer Primär-Kondensatableiter Inverted bucket primary steam trap Purgeur de vapeur primaire à flotteur à cloche	0-1.5bar 0-4bar		1	1	1	1	1	1	2577016	
				1	1	1	1	1	1	2577017	
108	Kugelschwimmer Primär-Kondensatableiter Ball float primary steam trap Purgeur de vapeur primaire à flotteur sphérique			1	1	1				2577015	
							1	1	2511407		
109	Thermischer Sekundär-Kondensatableiter Thermostatic secondary steam trap Purgeur de vapeur thermostatique secondaire		1	1	1	1		1	1	2577013	
										2577014	
110	Manometer Manometer Manomètre	0-2.5bar 0-6bar		1	1	1				1114634	
				1	1	1			1114635		
111	Manometer rostfrei Manometer stainless Manomètre inoxydable	0-2.5bar 0-6bar						1	1	1114636	
							1	1	1114637		
112	Einschraubwinkel Male elbow connector Coude mâle	1/2" 1/2", Niro	1	1	1	1				2547084	
							1	1	2547085		
113	Winkelverschraubung zu Primär-Kondensatableiter Male elbow connector for primary steam trap Coude mâle pour purgeur de vapeur primaire	1/2", ø12, Niro						1	1	1118112	
114	Schwenkverschraubung zu Primär-Kondensatableiter Male elbow connector rotary for primary steam trap Coude mâle rotatif pour purgeur de vapeur primaire	1/2", ø15		1	1	1				1104214	
115	Einstellnippel Adjustable male adapter Union orientable mâle	1/2", ø15 1/2", ø12, Niro		1	1	1				1118113	
							1	1	1118114		

Esco Niro

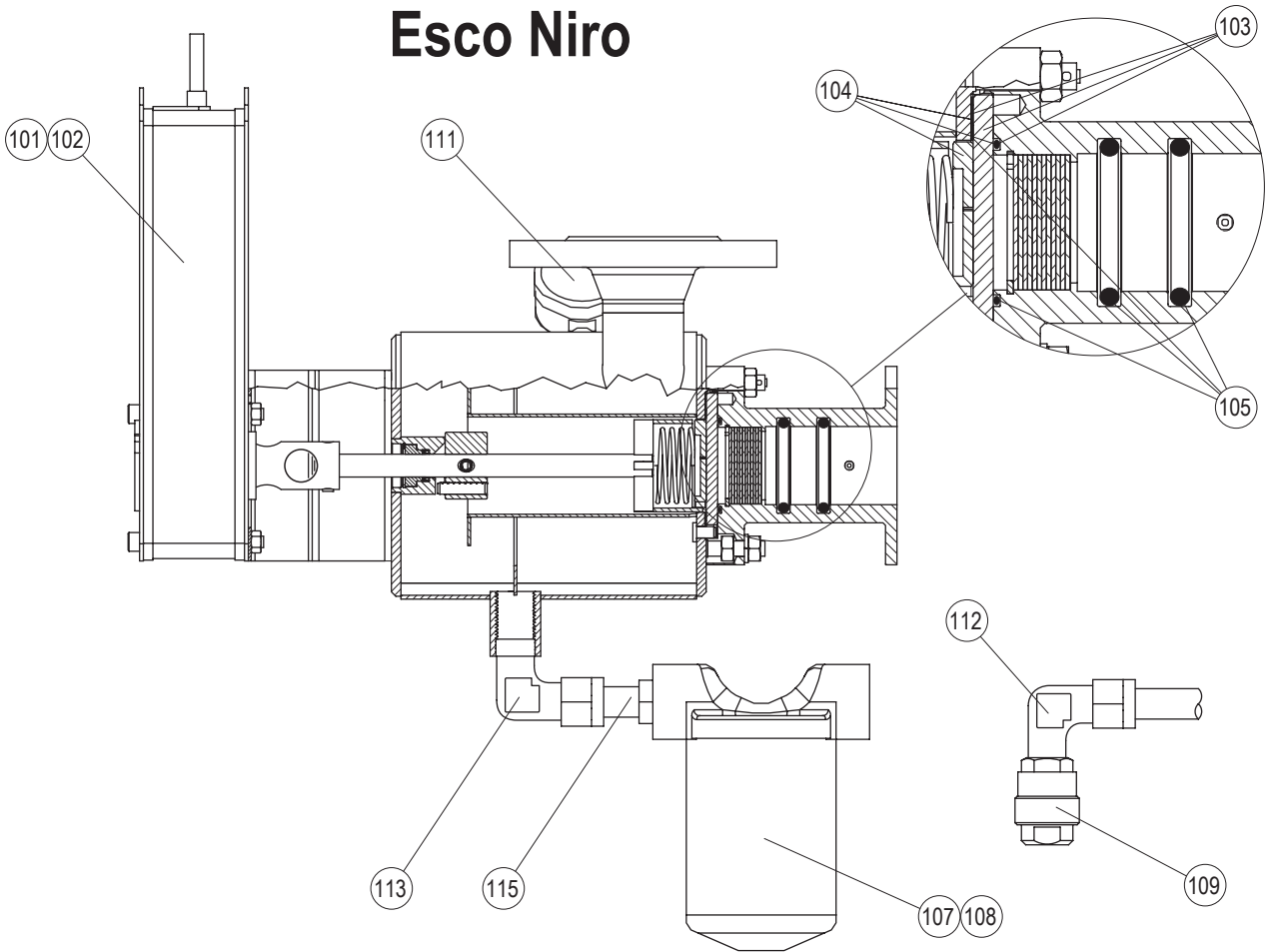

Esco 10/20/30

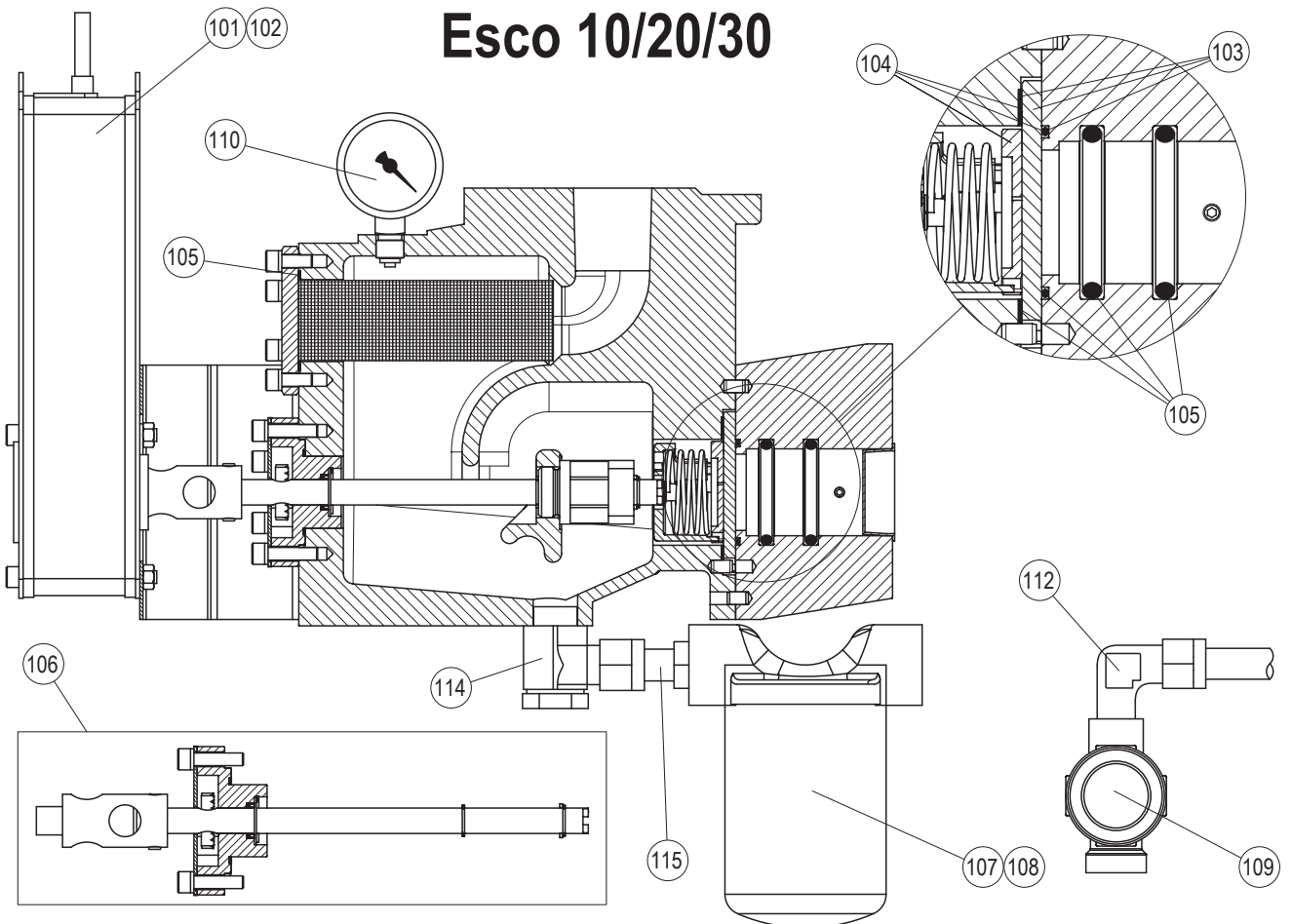

Esco 5

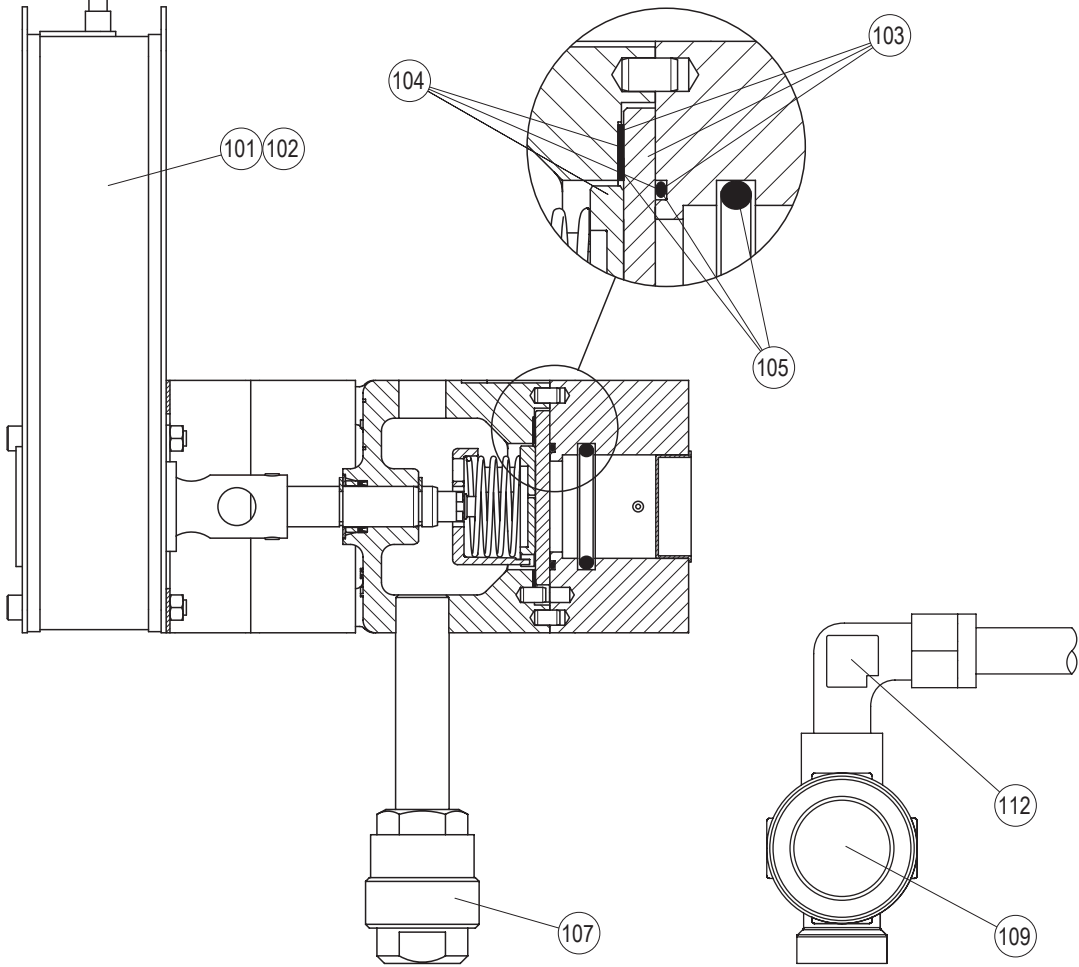

Manufacturer:
Condair Ltd.
Talstrasse 35-37, 8808 Pfäffikon, Switzerland
Ph. +41 55 416 61 11, Fax +41 55 416 62 62
info@condair.com, www.condair.com